

Characteristics / Ordering Code

2-way flow control valves series 2F1C provide pressure and viscosity compensated flow from port A to port B. The counter direction is blocked (standard) or can be open via an integral reverse flow check valve (optional).

Function

The compensator spool is located in front of the metering spool. The metering spool is closed in the neutral position to avoid undesired initial actuator motion. The oil flow to open the metering spool has to pass a needle valve (not shown in the sectional drawing). The needle valve can be adjusted from the front panel to set the response time of the 2F1C.

The metering spool is adjusted by the main control knob. The key lock has three positions:

- Lock: Adjustment is locked.
- Adjust: Full adjustment is permitted.
- Trim: Fine adjustment of $\pm 5\%$ is possible.

Features

- 2-way flow control valve
- Subplate mounting according to ISO 6263
- Excellent fine adjustment
- Adjustable response time
- Closed in neutral position
- Optional reverse flow check valve
- 2 sizes, NG10 (3/8"), NG16 (3/4")

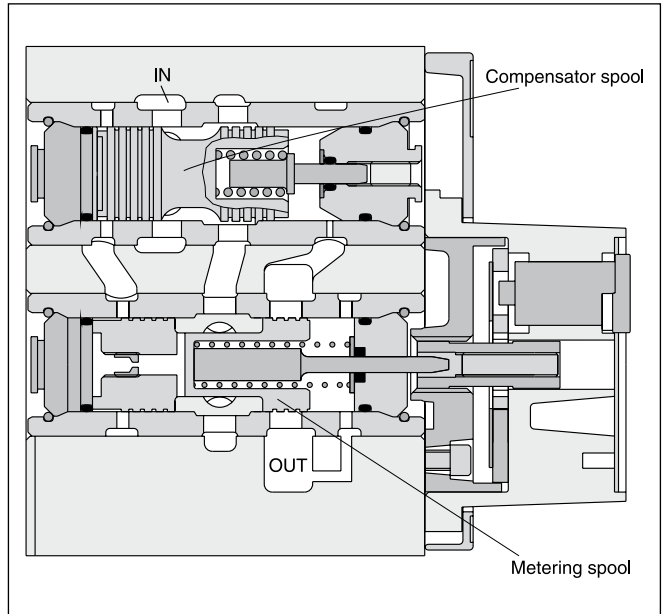
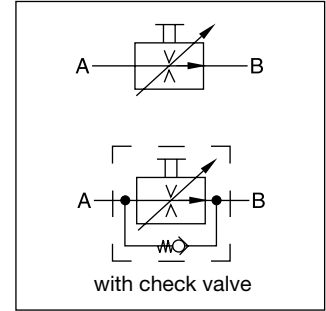
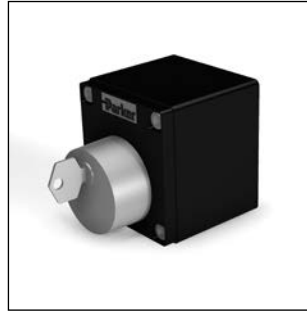

5

Ordering code

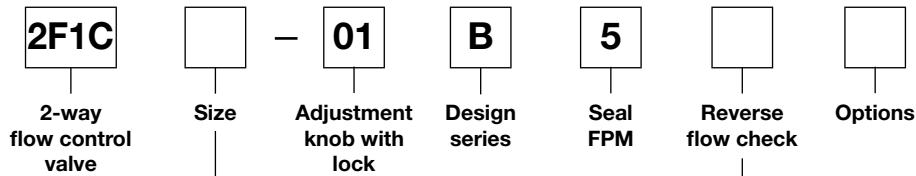

Code	Size
02	NG10 (3/8")
03	NG16 (3/4")

Code	Check valve
0	without check
C	with check

Technical Data

General			
Design	Orifice, infinitely variable, pressure-compensated		
Actuator	Manual flow rate adjustment		
Mounting type	ISO 6263		
Mounting position	unrestricted		
MTTF _D value	[years]	150	
Weight	[kg]	6.0 (2F1C02), 9.0 (2F1C03)	
Ambient temperature	[°C]	-20...+60	
Fluid	Hydraulic oil according to DIN 51524		
Fluid temperature	[°C]	-20...+70	
Viscosity, permitted recommended	[cSt] / [mm ² /s]	20 ... 400	
	[cSt] / [mm ² /s]	30 ... 80	
Filtering	ISO 4406 (1999); 18/16/13		
Min. pressure difference	[bar]	see diagram	
Max. operating pressure		2F1C02	2F1C03
	Port A	[bar] 14...280	14...350
	Port B	[bar] 0...270	0...340
Flow direction	A → B	Flow control function blocked or free flow through check valve	
	B → A		

5

Performance curves

Flow / knob adjustment characteristics at 210 bar

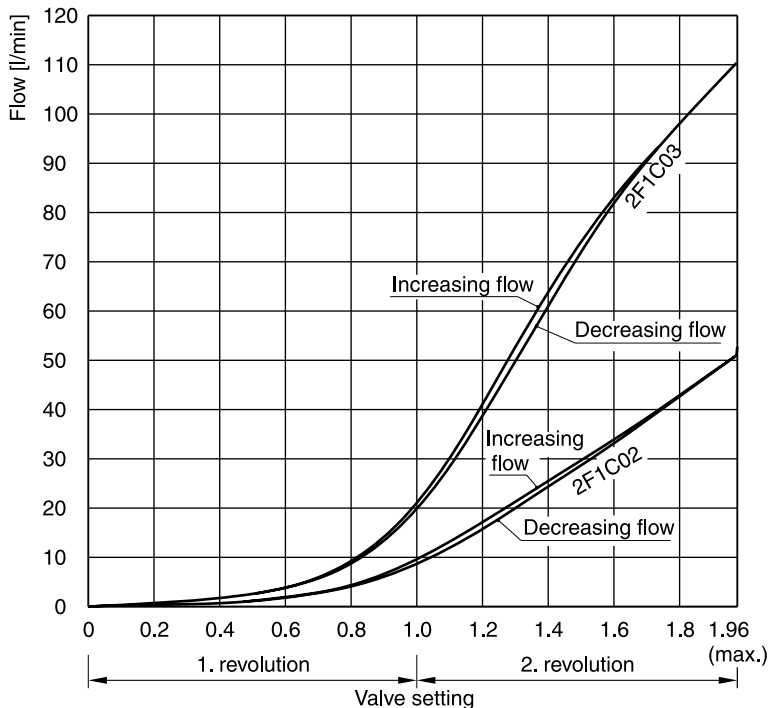

Flow / pressure drop curves

Constant inlet pressure – variable outlet pressure

2F1C02

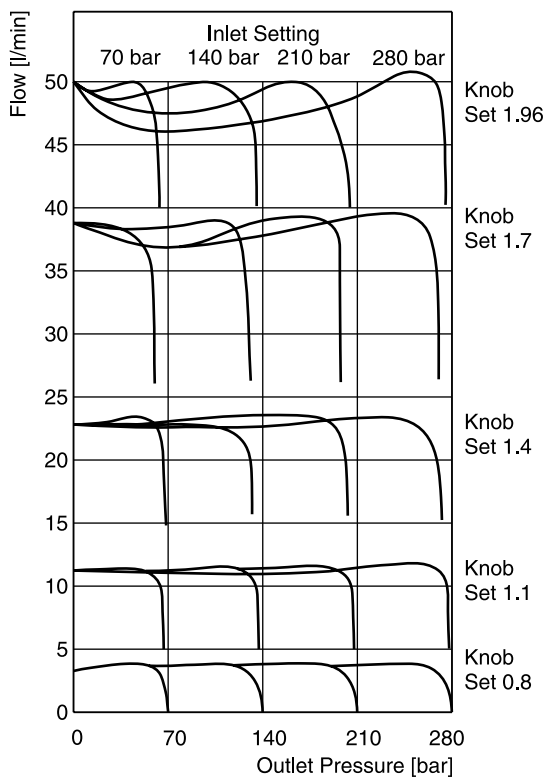

2F1C03

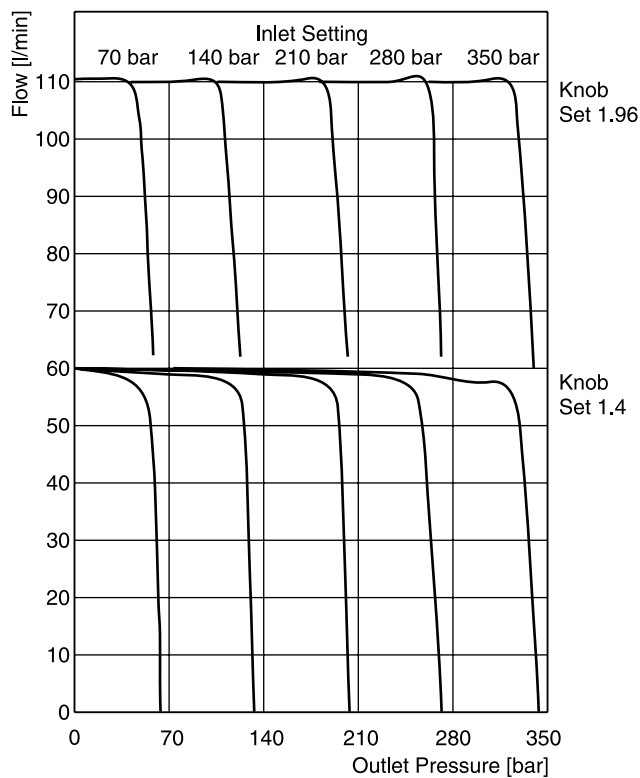

All characteristic curves measured with HLP46 at 50 °C.

5

$\Delta p/Q$ performance curves

for reverse flow direction
 2F1C02 at 280 bar
 2F1C03 at 350 bar

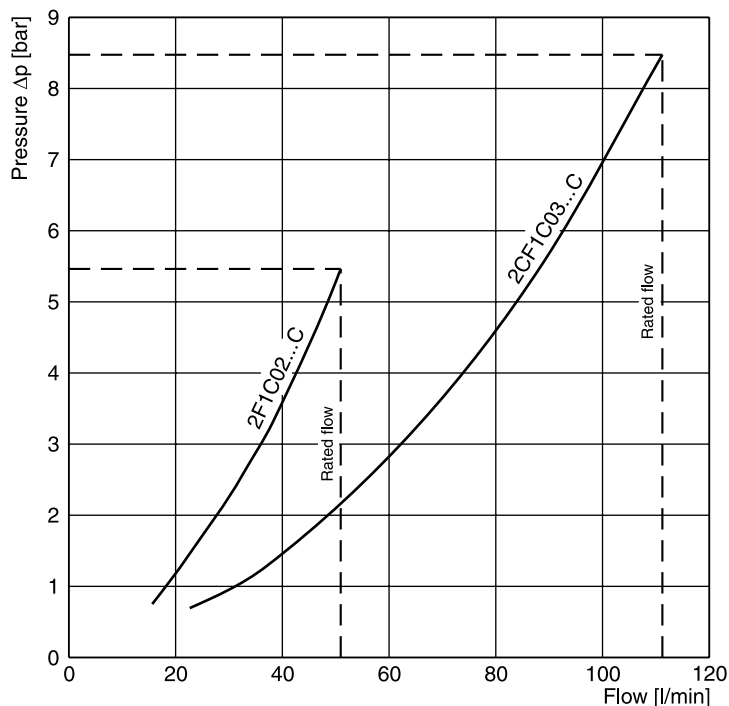

5

Minimum pressure difference curves

2F1C02

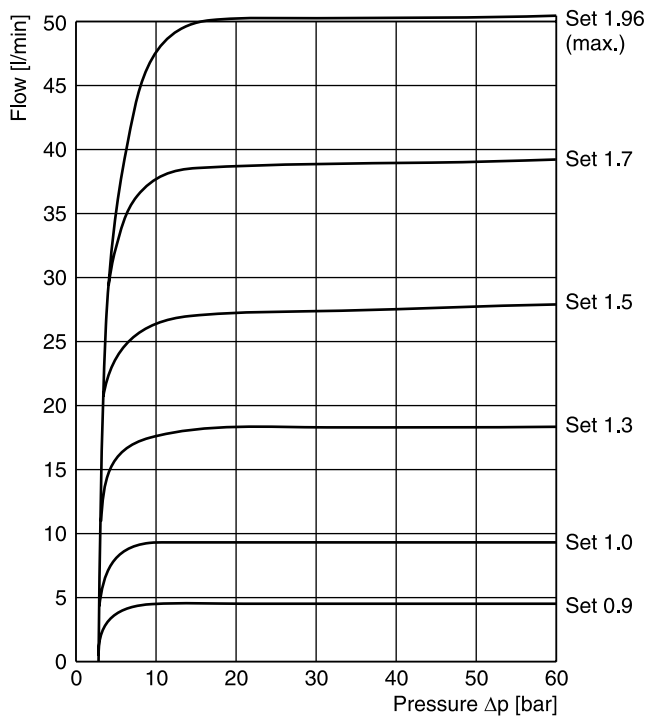

2F1C03

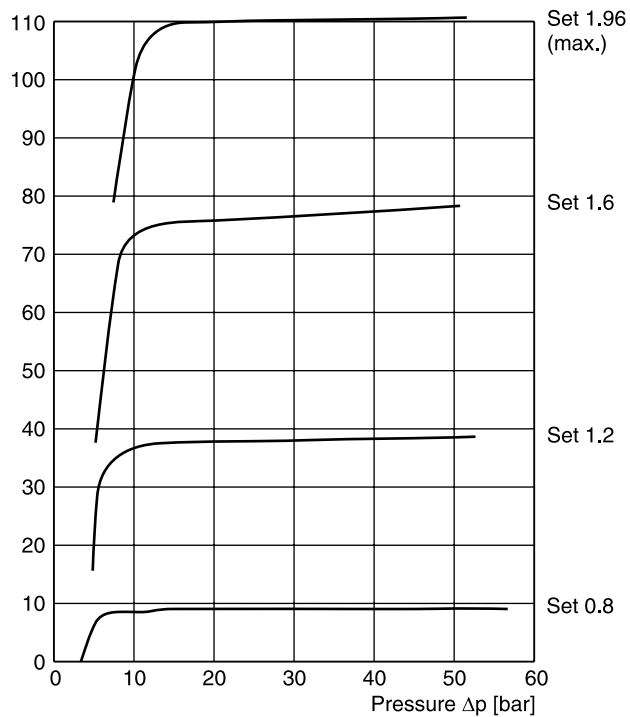

All characteristic curves measured with HLP46 at 50 °C.

Leakage / pressure curves

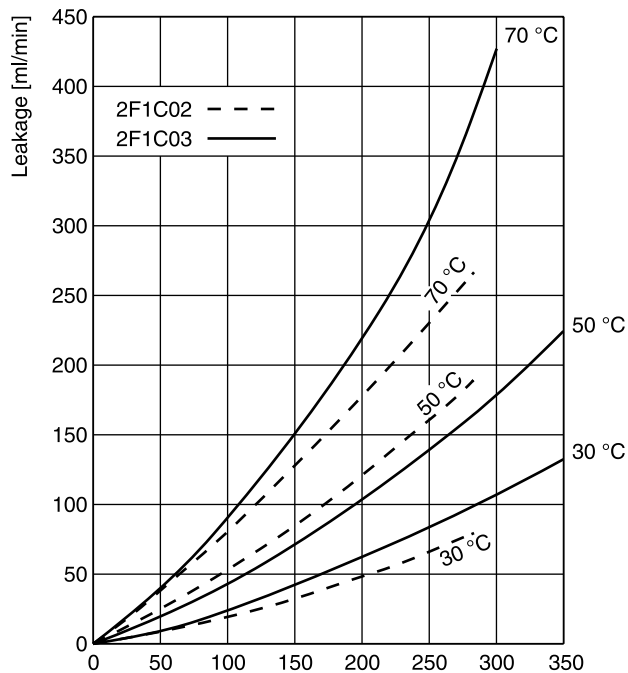

Flow / temperature curves at 210 bar

2F1C02

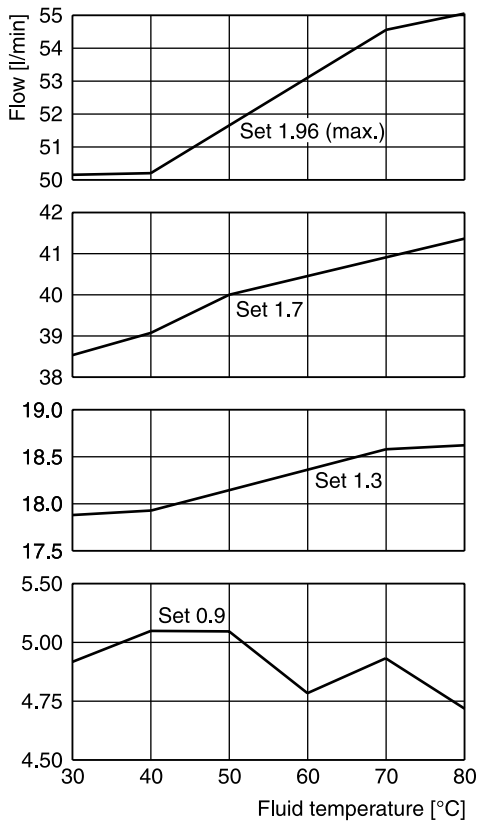

2F1C03

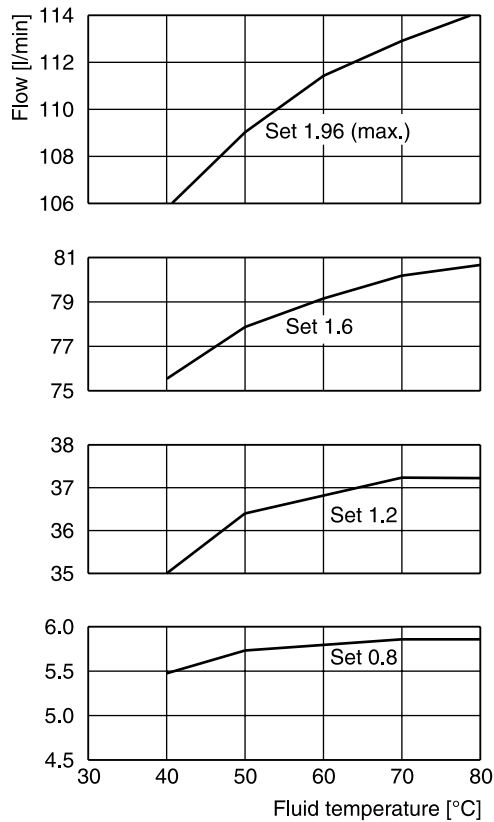

All characteristic curves measured with HLP46 at 50 °C.

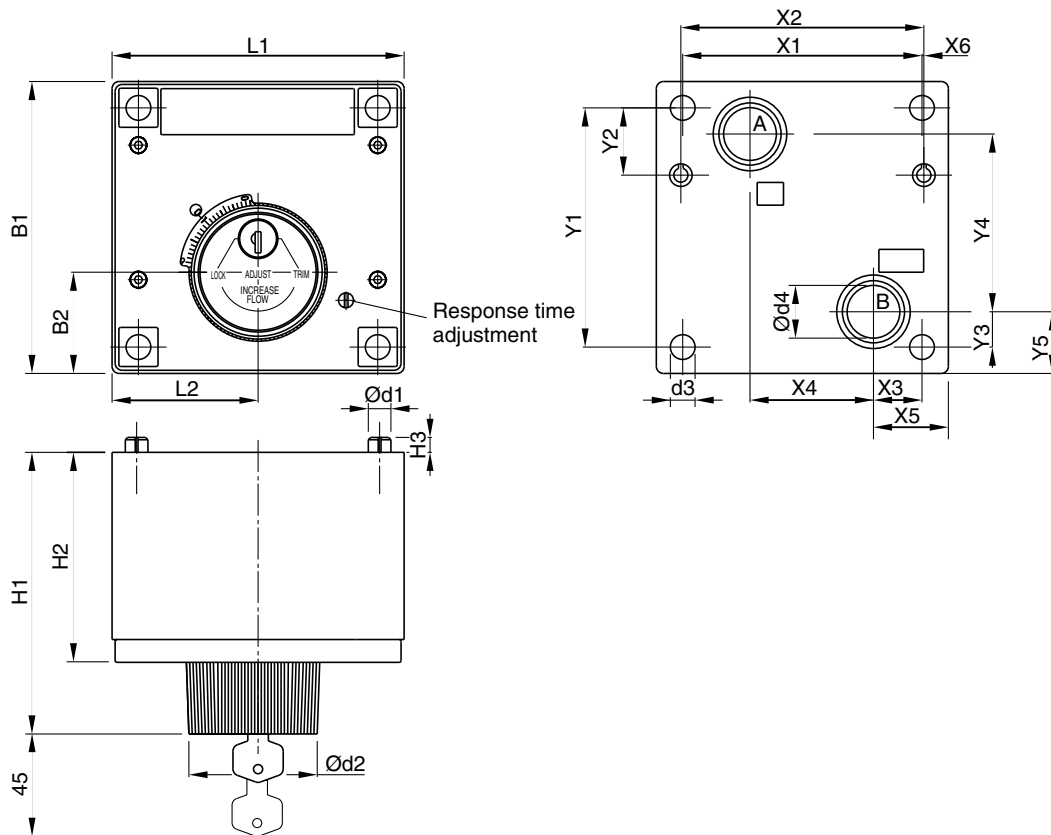

5



5

Size	ISO-code	x1	x2	x3	x4	x5	x6	y1	y2	y3	y4	y5
02	6263-AM-07-2-A	76.2	79.4	9.5	44.5	19	-	82.5	23.8	30.2	41.3	39.7
03	6263-AK-06-2-A	101.6	103.2	20.6	52.4	31.8	0.8	101.6	28.6	15.1	75.4	26.2

Size	ISO-code	B1	B2	H1	H2	H3	L1	L2	d1	d2	d3	d4
02	6263-AM-07-2-A	101.6	38.1	119.6	87.4	6.4	95.2	47.6	6.4	57.2	8.7	14.2
03	6263-AK-06-2-A	124	42.9	121.4	89.2	6.4	124	62	9.5	57.2	10.5	22.4

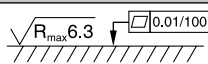
NG	ISO-code	Bolt kit -  ISO 4762-12.9 	Kit 	Surface finish 
02	6263-AM-07-2-A	BK538 4x M8x95	31.8 Nm ±15 %	on request
03	6263-AK-06-2-A	BK539 4x M10x95	63 Nm ±15 %	on request